

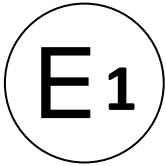

Kraftfahrt-Bundesamt

DE-24932 Flensburg



MITTEILUNG

ausgestellt von:

Kraftfahrt-Bundesamt

über die Erweiterung einer Genehmigung für einen Schutzhelmtyp mit einem Visiertyp(en) nach der Regelung Nr. 22 einschließlich Änderung Nr. 06 Ergänzung 01

COMMUNICATION

issued by:

Kraftfahrt-Bundesamt

concerning the extension of an approval of a type of protective helmet with one visor type(s) pursuant to Regulation No. 22 including amendment No. 06 supplement 01

Genehmigungsnummer: **E1*22R06/01*300939*01**

Approval number:

1. Fabrik- oder Handelsmarke:
Trade name or mark:
JUST1, ORIGINE, TORC, VCAN, Eldorado, J1, TANKED RACING, NITEK, ROCC, RJAYS, SCORPION, ROOK HELMETS, JOHNNY REB, GERMOT, LEVIOR, NEXO, CRAFT, SQ, protectWEAR, AKIRA, Hayder Motorcycles, römer, rueger-helmets, EOLE, KSK,130R, AMOQ, CMS, FASTR, RAVEN, YOKO, W-TEC, HYPE HELMETS, BEFAST, PROGRIP, Bogotto, BIKE IT, ViPER, VPR, 3GO, 3GO Helmets, RSX, ZORAX, DEXTER, PROV, KENNY, Benelli, S-LINE, SWAP'S, GASOLINE, aprilia, MOTO GUZZI, PIAGGIO, VESPA, Z1R, SSY, Ajax, ROOST
2. Typ:
Type:
H153
3. Größen:
Sizes:
XS(53/54), S(55/56), M(57/58), L(59/60), XL(61)
4. Name des Herstellers:
Manufacturer's name:
**SHANGHAI HEHUI SAFETY PRODUCTS MANUFACTURE CO., LTD.
CN-201401 Fengxian, Shanghai**



Kraftfahrt-Bundesamt

DE-24932 Flensburg

2

Genehmigungsnummer: **E1*22R06/01*300939*01**

Approval Number:

5. Anschrift:
 Address:
 Siehe Punkt 4.
 See item 4.

6. Name des Vertreters des Herstellers (gegebenenfalls):
 Name of manufacturer's representative (if any):
 Entfällt
 Not applicable

7. Anschrift:
 Address:
 Siehe Punkt 6.
 See item 6.

8. Kurze Beschreibung des Helms:
 Brief description of helmet:
 Siehe Anlagen
 See enclosures

9. **Helm mit schützender unterer Gesichtsabdeckung (P)**
 Helmet with protective lower face cover (P)

10. Visiertyp oder Visiertypen:
 Type of visor or visors:
 H-16
 E1 22R 06300934

11. Kurze Beschreibung des Visiers oder der Visiere:
 Brief description of visor(s):
 Siehe Anlagen
 See enclosures

12. Zur Genehmigung vorgelegt am:
 Submitted for approval on:
 12.01.2023

13. Technischer Dienst, der die Prüfungen für die Genehmigungen durchführt:
 Technical service responsible for conducting approval tests:
 SGS-TÜV Saar GmbH
 DE-81379 München

14. Datum des Gutachtens des Technischen Dienstes:
 Date of report issued by that service:
 12.01.2023

R22 E1*22R06/01*300939*01



Kraftfahrt-Bundesamt

DE-24932 Flensburg

3

Genehmigungsnummer: **E1*22R06/01*300939*01**

Approval Number:

15. Nummer des Gutachtens des Technischen Dienstes:
Number of report issued by that service:
HOM ECN T22/064-01

16. Bemerkung(en):
Remark(s):
Handelsbezeichnung(en):
General commercial description(s):
T153
H153B
H153 BT

Ausführung(en):

Version(s):

1

2

17. Die Genehmigung wird **erweitert**
Approval is **extended**

18. Ort: **DE-24932 Flensburg**
Place:

19. Datum: **26.01.2023**
Date:

20. Unterschrift: **Im Auftrag**
Signature:

(D. Stieglitz)





Kraftfahrt-Bundesamt

DE-24932 Flensburg

4

Genehmigungsnummer: **E1*22R06/01*300939*01**

Approval Number:

21. Folgende mit der oben erwähnten Genehmigungsnummer versehene Dokumente sind auf Anforderung erhältlich:
The following documents, bearing the approval number shown above, are available on request:

Anlagen:

Enclosures:

Gemäß Inhaltsverzeichnis

According to index



Kraftfahrt-Bundesamt

DE-24932 Flensburg

Zu: E1*22R06/01*300939*01

To:

Erklärung über die Einhaltung der Anforderungen hinsichtlich der Übereinstimmung der Produktion gemäß dem Übereinkommen von 1958
Statement of compliance with the conformity of the production requirements of the 1958 Agreement

1. Name des Herstellers:
Manufacturer's name:
SHANGHAI HEHUI SAFETY PRODUCTS MANUFACTURE CO., LTD.
CN-201401 Fengxian, Shanghai
2. Datum der Anfangsbewertung:
Date of the initial assessment:
30.09.2014
3. Datum aller durchgeführten Überwachungstätigkeiten:
Date of any surveillance activities:

Aktenzeichen Register number	Datum der Begehung Date of inspection	Genehmigungsnummer Approval number
---------------------------------	--	---------------------------------------

CoP-Q:

Entfällt

Not applicable

CoP-P:

P-432-1-0042-10	18.05.2010	05300212
P-432-1-0100-10	15.06.2010	05300204
P-432-1-0140-11	20.09.2011	05300225
P-501697	27.06.2017	05300526, Erweiterung 04



Kraftfahrt-Bundesamt

DE-24932 Flensburg

Zu: **E1*22R06/01*300939*01**

To:

Inhaltsverzeichnis zu den Beschreibungsunterlagen Index to the information package

Ausgabedatum: **02.09.2022** Letztes Änderungsdatum: **26.01.2023**
Date of issue: Last date of amendment:

Nebenbestimmungen und Rechtsbehelfsbelehrung
Collateral clauses and instruction on right to appeal

Prüfbericht(e) Nr.:	Datum:
Test report(s) No.:	Date:
HOM ECN T22/064-00	26.08.2022
HOM ECN T22/064-01	12.01.2023

Beschreibungsbogen Nr.:	Datum:
Information document No.:	Date:
R22-H153-00	28.06.2022
R22-H153-01	04.11.2022

Liste der Änderungen:	Datum:
List of modifications:	Date:
Siehe Prüfbericht: "List of modifications"	12.01.2023
See test report: "List of modifications"	



Kraftfahrt-Bundesamt

DE-24932 Flensburg

Nummer der Genehmigung: **E1*22R06/01*300939*01**

- Anlage -

Nebenbestimmungen und Rechtsbehelfsbelehrung

Nebenbestimmungen

Jede Einrichtung, die dem genehmigten Typ entspricht, ist gemäß der angewendeten Vorschrift zu kennzeichnen.

Die Einzelerzeugnisse der reihenweisen Fertigung müssen mit den Genehmigungsunterlagen genau übereinstimmen. Änderungen an den Einzelerzeugnissen sind nur mit ausdrücklicher Zustimmung des Kraftfahrt-Bundesamtes gestattet.

Änderungen der Firmenbezeichnung, der Anschrift und der Fertigungsstätten sowie eines bei der Erteilung der Genehmigung benannten Zustellungsbevollmächtigten oder bevollmächtigten Vertreters sind dem Kraftfahrt-Bundesamt unverzüglich mitzuteilen.

Verstöße gegen diese Bestimmungen können zum Widerruf der Genehmigung führen und können überdies strafrechtlich verfolgt werden.

Die Genehmigung erlischt, wenn sie zurückgegeben oder entzogen wird, oder der genehmigte Typ den Rechtsvorschriften nicht mehr entspricht. Der Widerruf kann ausgesprochen werden, wenn die für die Erteilung und den Bestand der Genehmigung geforderten Voraussetzungen nicht mehr bestehen, wenn der Genehmigungsinhaber gegen die mit der Genehmigung verbundenen Pflichten - auch soweit sie sich aus den zu dieser Genehmigung zugeordneten besonderen Auflagen ergeben - verstößt oder wenn sich herausstellt, dass der genehmigte Typ den Erfordernissen der Verkehrssicherheit oder des Umweltschutzes nicht entspricht.

Das Kraftfahrt-Bundesamt kann jederzeit die ordnungsgemäße Ausübung der durch diese Genehmigung verliehenen Befugnisse, insbesondere die genehmigungsgerechte Fertigung sowie die Maßnahmen zur Übereinstimmung der Produktion, nachprüfen. Es kann zu diesem Zweck Proben entnehmen oder entnehmen lassen. Dem Kraftfahrt-Bundesamt und/oder seinen Beauftragten ist ungehinderter Zutritt zu Produktions- und Lagerstätten zu gewähren.

Die mit der Erteilung der Genehmigung verliehenen Befugnisse sind nicht übertragbar. Schutzrechte Dritter werden durch diese Genehmigung nicht berührt.

Rechtsbehelfsbelehrung

Gegen diese Genehmigung kann innerhalb eines Monats nach Bekanntgabe Widerspruch erhoben werden. Der Widerspruch ist beim **Kraftfahrt-Bundesamt, Fördestraße 16, DE-24944 Flensburg**, schriftlich oder zur Niederschrift einzulegen.



Kraftfahrt-Bundesamt

DE-24932 Flensburg

2

Approval No.: **E1*22R06/01*300939*01**

- Attachment -

Collateral clauses and instruction on right to appeal

Collateral clauses

All equipment which corresponds to the approved type is to be identified according to the applied regulation.

The individual production of serial fabrication must be in exact accordance with the approval documents. Changes in the individual production are only allowed with express consent of the Kraftfahrt-Bundesamt.

Changes in the name of the company, the address and the manufacturing plant as well as one of the parties given the authority to delivery or authorised representative named when the approval was granted is to be immediately disclosed to the Kraftfahrt-Bundesamt.

Breach of this regulation can lead to recall of the approval and moreover can be legally prosecuted.

The approval expires if it is returned or withdrawn or if the type approved no longer complies with the legal requirements. The revocation can be made if the demanded requirements for issuance and the continuance of the approval no longer exist, if the holder of the approval violates the duties involved in the approval, also to the extent that they result from the assigned conditions to this approval, or if it is determined that the approved type does not comply with the requirements of traffic safety or environmental protection.

The Kraftfahrt-Bundesamt may check the proper exercise of the conferred authority taken from this approval at any time. In particular this means the compliant production as well as the measures for conformity of production. For this purpose samples can be taken or have taken. The employees or the representatives of the Kraftfahrt-Bundesamt may get unhindered access to the production and storage facilities.

The conferred authority contained with issuance of this approval is not transferable. Trade mark rights of third parties are not affected with this approval.

Instruction on right to appeal

This approval can be appealed within one month after notification. The appeal is to be filed in writing or as a transcript at the **Kraftfahrt-Bundesamt, Fördestraße 16, DE-24944 Flensburg.**

Technical Report

V00

Test standard:
ECE Regulation No. 22

Level of amendment:
Supplement 1 to the 06 series of amendments

Title:
Protective helmets and their visors

Manufacturer:
SHANGHAI HEHUI SAFETY PRODUCTS MANUFACTURE CO., LTD.

Type:
H153

Subject of testing:
Component

0 General

- 0.1 Make
(trade name of manufacturer): JUST1, ORIGINE, TORC, VCAN, Eldorado, J1, TANKED RACING, NITEK, ROCC, RJAYS, SCORPION, ROOK HELMETS, JOHNNY REB, GERMOT, LEVIOR, NEXO, CRAFT, SQ, protectWEAR, AKIRA, Hayder Motorcycles, römer, rueger-helmets, EOLE, KSK, 130R, AMOQ, CMS, FASTR, RAVEN, YOKO, W-TEC, HYPE HELMETS, BEFAST, PROGRIP, Bogotto, BIKE IT, ViPER, VPR, 3GO, 3GO Helmets, RSX, ZORAX, DEXTER, PROV, KENNY, Benelli, S-LINE, SWAP'S, GASOLINE, aprilia, MOTO GUZZI, PIAGGIO, VESPA, Z1R, SSY, Ajax, ROOST

- 0.2 Type: H153

- 0.2.1 Commercial description(s): T153, H153B, H153 BT

- 0.2.2 Variants/ versions: Version 1: Helmet without additional device
Version 2: Helmet with additional device

- 0.3 Means of identification of type, if marked on the vehicle / component / technical unit: refer to information document

- 0.3.1 Location of that marking: refer to information document

- 0.4 Category of vehicle: n.a.

- 0.5 Manufacturer's name and address: SHANGHAI HEHUI SAFETY PRODUCTS MANUFACTURE CO., LTD.
NO.8 FENGJIN ROAD XIDU INDUSTRIAL DEVELOPMENT ZONE FENGXIAN DISTRICT SHANGHAI CHINA

- 0.8 Name(s) and address(es) of assembly plant(s): SHANGHAI HEHUI SAFETY PRODUCTS MANUFACTURE CO., LTD.
NO.8 FENGJIN ROAD XIDU INDUSTRIAL DEVELOPMENT ZONE FENGXIAN DISTRICT SHANGHAI CHINA

- 0.9 Name and address of representative: n.a.

- 0.10 Location of the ECE approval mark: refer to information document

R22 E1*22R06/01*300939*01

1 Test record

See appendix

2 Attachments

2.1 List of modifications:

2.2 Information folder: No.: R22-H153-01

Date of issue: 04.11.2022

3 Statement of conformity:

The information folder as mentioned under no. 2.2 and the type described therein are in compliance with the test standard mentioned above. With regard to the required level of performance to be achieved, the test specimen were representative for the type to be approved.

The tests were carried out in accordance to the relevant requirements of the

EN ISO/IEC 17025 EN ISO/IEC 17020

Test Laboratory
SGS-TÜV Saar GmbH

notified by

Kraftfahrt-Bundesamt (KBA),
Federal Republic of Germany

National Standards
Authority of Ireland (NSAI)

Rijksdienst voor het
Wegverkeer (RDW),
The Netherlands

No. KBA - P 00084 – 10

No. 101

No. 99050064 00

Responsible expert

Signature

Stephen He
12.01.2023



Conformity check

Signature

Cinney Zhang



This Technical Report shall be reproduced and published in full only and by the client only. It shall be reproduced partially with the written permission of the Test Laboratory only.

This document is issued by the Company subject to its General Conditions of Service (www.sgsgroup.de/agb). Attention is drawn to the limitations of liability, indemnification and jurisdictional issues established therein. This document is an original. If the document is submitted digitally, it is to be treated as an original within the meaning of UCP 600. Any holder of this document is advised that information contained hereon reflects the Company's findings at the time of its intervention only and within the limits of client's instructions, if any. The Company's sole responsibility is to its Client and this document does not exonerate parties to a transaction from exercising all their rights and obligations under the transaction documents. Any unauthorized alteration, forgery or falsification of the content or appearance of this document is unlawful and offenders may be prosecuted to the fullest extent of the law.

To assess the conformity, the laboratory refers to the "scope classification" of the Kraftfahrt-Bundesamt (KBA) – Federal Motor Transport Authority (in its valid version at the time of testing) and the specified consideration of the measurement uncertainty for the related test procedure.

In case the measurement uncertainty does not need to be considered according to the scope classification, the laboratory considers the result conform if its measured value is within the specification.

In case the measurement uncertainty does need to be considered according to the scope classification, the laboratory considers the result conform if its value incl. its measurement uncertainty is within the specification.

Test record

1 Test object and measuring equipment

1.1 Test object

- Protective helmet (without visor)
- Protective helmet (with visor)
- Visor (protective screen)
- Sun shield (additional tinted screen)

1.1.1 Protective Helmet

Type: H153
 Sizes: XS(53/54), S(55/56), M(57/58), L(59/60), XL(61)
 Helmet types:

- (J) Jet
- (P) Full face
- (NP) Jet
- (P/J) Modular helmet

1.1.2 Visor

Type: H-16
 Refer to approval no.: E1 22R 06300934

1.1.3 Sun shield

Type: H153SV
 Brief description: Tinted screen in combination with clear visor, three dimensional injected, PC material
 Types of helmet to which the sun shield may be fitted: H153, T153, H153B, H153 BT

1.1.4 Remarks:

1.2 Equipments for measuring and testing:

1.2.1 Test equipment:

The equipment and the test facilities on which the tests were carried out fulfilled the requirements of the ECE Regulation 22.06

1.2.2 Measurement procedure:

according to ECE Regulation No. 22.06

2 Test Results

Due to the reason of extension (see attachment 2.1 List of modifications), only Test for projections and surface friction and retention system are required. The former test results still remain valid.

2.1 Protective helmet

2.1.17 Test method for projections and surface friction

- Procedure A (7.4.1)
- Procedure B (7.4.2)

Helmet No.	Condition	Helmet Size (cm)	Projections	Friction
M-1	Ambient-temperature and Hygrometry Conditioning	57-58	Pass	Pass

2.2 Retention system

2.2.1 The retention system is protected from abrasion (clause 6.10)

- fulfilled
- Not fulfilled
- n.a.

2.2.2 Chin strap (clause 6.11.1, 6.11.2)

The width of the chin strap is more than 20 mm under load of 150 N and it doesn't include a chin-cup.

- fulfilled
- Not fulfilled
- n.a.

2.2.3 Adjustment device (clause 6.11.3)

The retention system includes a device to adjust and maintain tension.

- fulfilled
- Not fulfilled
- n.a.

2.2.4 Fastening devices (clauses 6.11.4 to 6.11.9)

The requirements for fastening devices and release mechanisms are in accordance to the requirements of the test standard.

- | | | |
|-------|--|---|
| | | <input checked="" type="checkbox"/> fulfilled
<input type="checkbox"/> Not fulfilled
<input type="checkbox"/> n.a. |
| 2.2.5 | Pulling flap
(clauses 6.11.6) | In red and its dimensions more than 10 x 20mm
<input checked="" type="checkbox"/> fulfilled
<input type="checkbox"/> Not fulfilled
<input type="checkbox"/> n.a. |
| 2.2.6 | Dynamic Test of the Retention System
(clause 7.6) | <input checked="" type="checkbox"/> fulfilled
<input type="checkbox"/> Not fulfilled
<input type="checkbox"/> n.a. |

Helmet No.	Condition	Helmet Size (cm)	Dynamic displacement (≤ 35 mm)	Residual displacement (≤ 25 mm)
XS-1	Ambient-temperature and Hygrometry Conditioning	53-54	33.6	17.5

- | | | |
|-------|--|--|
| 2.2.7 | Retention (detaching) test
(clause 7.7) | <input checked="" type="checkbox"/> fulfilled
<input type="checkbox"/> Not fulfilled
<input type="checkbox"/> n.a. |
|-------|--|--|

Helmet No.	Condition	Helmet Size (cm)	Movement of the reference line (≤ 30°)	
			Backward	Frontward
XS-1	Ambient-temperature and Hygrometry Conditioning	53-54	22°	5°

- | | | |
|-------|--|--|
| 2.2.8 | Micro-slip test of the chin strap
(clause 7.10) | <input checked="" type="checkbox"/> fulfilled
<input type="checkbox"/> Not fulfilled
<input type="checkbox"/> n.a. |
|-------|--|--|

Slippage of chin strap: (≤ 10mm): <5 mm

R22 E1*22R06/01*300939*01

2.2.9	Chin strap, resistance to abrasion test (clause 7.11)	<input checked="" type="checkbox"/> fulfilled <input type="checkbox"/> Not fulfilled <input type="checkbox"/> n.a.
2.2.9.1	Chin strap, withstand a tension of 3 kN (clause 7.11.5)	<input checked="" type="checkbox"/> fulfilled <input type="checkbox"/> Not fulfilled <input type="checkbox"/> n.a.
2.2.10	Retention systems relying on quick-release mechanisms (clause 7.12)	
2.2.10.1	Inadvertent release by pressure (clause 7.12.1)	<input type="checkbox"/> fulfilled <input type="checkbox"/> Not fulfilled <input checked="" type="checkbox"/> n.a.
2.2.10.2	Ease of release (clause 7.12.2)	<input checked="" type="checkbox"/> fulfilled <input type="checkbox"/> Not fulfilled <input type="checkbox"/> n.a.
2.2.10.3	Durability of quick-release mechanisms (clause 7.12.3)	<input checked="" type="checkbox"/> fulfilled <input type="checkbox"/> Not fulfilled <input type="checkbox"/> n.a.
2.3	Visor	<input type="checkbox"/> n.a. (no) <input checked="" type="checkbox"/> n.a. (separately approved)
		Refer to approval no.: E1 22R 06300934
2.4	Sun shield	The former test results remain valid.
2.5	Information for wearers (clauses 14.1 to 14.6)	The former test results remain valid.
3	Other information	
	Place of testing:	SGS CSTC Guangzhou, P.R. China
	Date of testing:	From 08.08.2022 to 21.08.2022 From 14.11.2022 to 28.11.2022

R22 E1*22R06/01*300939*01



Technical Report
No.: HOM ECN T22/064-01
Type: H153
Appendix

4 **Remarks:** ---

List of modifications

- | | | |
|---|------------------|---|
| 1 | Correction of: | n.a. |
| 2 | Modification of: | modify Variants / Versions to "Version 1: Helmet without additional device" & "Version 2: Helmet with additional device" |
| 3 | Addition of: | <ol style="list-style-type: none">1. Commercial description(s) add "H153B, H153 BT"2. Type(s) of helmet to which may be Equipped with this sun shield add "H153B, H153 BT"3. Add retention system 2 |
| 4 | Deletion of: | n.a. |

INFORMATION DOCUMENT

No.: R22-H153-01



SHANGHAI HEHUI SAFETY PRODUCTS MANUFACTURE CO., LTD.

TYPE: H153

Protective helmet with sun shield
pursuant to

Regulation No. 22

UNIFORM PROVISIONS CONCERNING THE APPROVAL OF
PROTECTIVE HELMETS AND THEIR VISORS FOR DRIVERS AND
PASSENGERS OF MOTORCYCLES AND MOPEDS

Signature of a responsible person:

A handwritten signature in black ink, appearing to be 'J. Hehui'.

Date: 04.11.2022

Reason of extension:

Correction: n.a.

Modification: modify Variants / Versions to "Version 1: Helmet without additional device" &
"Version 2: Helmet with additional device"

Addition: 1. Commercial description(s) add "H153B, H153 BT"

2. Type(s) of helmet to which may be Equipped with this sun shield add "H153B, H153
BT"

3. Add retention system 2

Deletion: n.a.



Type : H153
 Manufacture : SHANGHAI HEHUI SAFETY PRODUCTS
 MANUFACTURE CO., LTD.

04.11.2022

Page 2 of 21

- 0**
- 0.1 Make (trade name of manufacturer) : JUST1, ORIGINE, TORC, VCAN, Eldorado, J1, TANKED RACING, NITEK, ROCC, RJAYS, SCORPION, ROOK HELMETS, JOHNNY REB, GERMOT, LEVIOR, NEXO, CRAFT, SQ, protectWEAR, AKIRA, Hayder Motorcycles, römer, rueger-helmets, EOLE, KSK,130R, AMOQ, CMS, FASTR, RAVEN, YOKO, W-TEC, HYPE HELMETS, BEFAST, PROGRIP, Bogotto, BIKE IT, ViPER, VPR, 3GO, 3GO Helmets, RSX, ZORAX, DEXTER, PROV, KENNY, Benelli, S-LINE, SWAP'S, GASOLINE, aprilia, MOTO GUZZI, PIAGGIO, VESPA, Z1R, SSY, Ajax, ROOST
 - 0.2 Type and general commercial description : H153
 - 0.2.1 Commercial description(s) : T153, H153B, H153 BT
 - 0.3 Variants / Versions : Version 1: Helmet without additional device
Version 2: Helmet with additional device
 - 0.4 Name and address of manufacturer : SHANGHAI HEHUI SAFETY PRODUCTS
MANUFACTURE CO., LTD.
NO.8 FENGJIN ROAD XIDU INDUSTRIAL
DEVELOPMENT ZONE FENGXIAN DISTRICT
SHANGHAI CHINA
 - 0.5 Name and address of assembly plant : SHANGHAI HEHUI SAFETY PRODUCTS
MANUFACTURE CO., LTD.
NO.8 FENGJIN ROAD XIDU INDUSTRIAL
DEVELOPMENT ZONE FENGXIAN DISTRICT
SHANGHAI CHINA
 - 0.6 Name and address of manufacturer's authorized representative(if any) : n.a.
 - 0.7 Location and method of affixing of the international approval mark : Marked in a label sewn on the retention system, see Annex 6
 - 1 TECHNICAL DESCRIPTION**
 - 1.1 Description of the helmet
 - 1.1.1 Type of helmet : Full face
 - 1.1.2 Type of lower face cover : "P" protective
 - 1.1.3 Size(s) (cm) : XS(53-54), S(55-56), M(57-58), L(59-60), XL(61)
 - 1.1.4 Drawing of the helmet : see Annex 1
 - 1.2 Description of the visor : type: H-16
Refer to approval no.: E1 22R 06300934
 - 1.3 Description of the sun shield :
 - 1.3.1 Material : PC
 - 1.3.2 Color : Tinted
 - 1.3.3 Thickness : 1.3±0.1 mm
 - 1.3.4 Transmittance : 20-50%
 - 1.3.5 Manufacture method : By injection
 - 1.3.6 Type(s) of helmet to which may be Equipped with this sun shield : H153, T153, H153B, H153 BT
 - 1.3.7 Drawing of the sun shield : see Annex 2

R22 E1*22R06/01*300939*01

INFORMATION DOCUMENT

R22-H153-01



Type : H153
 Manufacture : SHANGHAI HEHUI SAFETY PRODUCTS
 MANUFACTURE CO., LTD.

04.11.2022

Page 3 of 21

- 1.4 Description of the shell
 - 1.4.1 Material : ABS
 - 1.4.2 Manufacture method : By injection
 - 1.4.3 Ventilation : see Annex 1
 - 1.4.4 Composition of the border join on the shell : PVC
 - 1.4.5 Drawing of the shell : see Annex 3
- 1.5 Description of protective padding
 - 1.5.1 Composition : EPS
 - 1.5.2 Density and weight

Size (cm)	Shell Type	Comfort padding thickness +Top Zone (mm)	EPS Density Main + Top + Ear + Insert (Kg/m ³)	EPS Padding Thickness (mm)	EPS Density Main + Top + Ear + Insert (grams)
XS (53-54)	L	12+12	58+26+50+75	30-45	58+63+16+5
S (55-56)	L	10+12	58+26+50+75	30-45	58+63+16+5
M (57-58)	L	8+12	58+26+50+75	30-45	58+63+16+5
L (59-60)	L	10+12	60+26+69+75	27.1-41.8	73+60+23+5
XL (61)	L	8+12	60+26+69+75	27.1-41.8	73+60+23+5

- 1.5.3 Drawing of the protective padding : see Annex 4
- 1.6 Description of comfort padding
 - 1.6.1 Composition of Comfort padding : Compound sponge
 - Comfort tissue : Compound cloth
 - Protection of the back of the nape : Compound sponge
 - Lateral packing : EPS and compound sponge
 - Lower face cover : EPS and PVC
 - 1.6.2 Drawing of the comfort padding : see Annex 5
- 1.7 Description of the retention system 1
 - 1.7.1 Chin strap
 - Material : Nylon Belt
 - Width : 22±1mm mm
 - 1.7.2 Retention system : Quick release buckle
 - 1.7.3 Comfort padding of the retention system
 - Composition : Leather and fabric
 - Thickness : 2 mm
 - 1.7.4 Anchorage system to the shell : By a metallic piece fitted to the internal part of the shell by a rivet
 - 1.7.5 Drawing of the retention system : see Annex 6
- 1.8 Description of the retention system 2
 - 1.8.1 Chin strap
 - Material : Nylon Belt
 - Width : 22±1mm mm
 - 1.8.2 Retention system : Double "D" Ring

R22 E1*22R06/01*300939*01



Type : H153
 Manufacture : SHANGHAI HEHUI SAFETY PRODUCTS
 MANUFACTURE CO., LTD.

04.11.2022

Page 4 of 21

1.8.3	Comfort padding of the retention system		
	Composition	:	<u>Leather and fabric</u>
	Thickness	:	<u>2 mm</u>
1.8.4	Anchorage system to the shell	:	<u>By a metallic piece fitted to the internal part of the shell by a rivet</u>
1.8.5	Drawing of the retention system	:	<u>see Annex 6</u>
1.9	Other Characteristics		
1.9.1	Markings		
	Make	:	Outer shell, different location depending on makers
	Weight	:	Rear part of the shell
	Size	:	Rear part of the shell
1.9.2	Indelible marking		
	How it is made	:	By sewing
	Position	:	On the chin strap
2.1	Accessories		
2.1.1	Peak	:	n.a.
2.1.2	Information for wearer		
2.1.2.1	Text	:	See Annex 7
2.1.2.2	Position	:	Weave inside rear part of the padding
	ANNEXS		
Annex 1	Drawing of the helmet		
	<u>H153 Helmet</u>		<u>04.11.2022</u>
Annex 2	Drawing of the sun shield		28.06.2022
Annex 3	Drawing of the shell		28.06.2022
Annex 4	Drawing of the protective padding		28.06.2022
Annex 5	Drawing of the comfort padding		28.06.2022
Annex 6	Drawing of the retention system		
	H153 Retention System (Right)		28.06.2022
	H153 Retention System (Left)		28.06.2022
	<u>H153 Chin Strap (Right)</u>		<u>04.11.2022</u>
	<u>H153 Chin Strap (left)</u>		<u>04.11.2022</u>
Annex 7	Information for wearer		28.06.2022

R22 E1*22R06/01*300939*01

INFORMATION DOCUMENT

R22-H153-01



Type : H153
 Manufacture : SHANGHAI HEHUI SAFETY PRODUCTS MANUFACTURE CO., LTD.

04.11.2022

Page 5 of 21

Annex 1: Drawing of the helmet

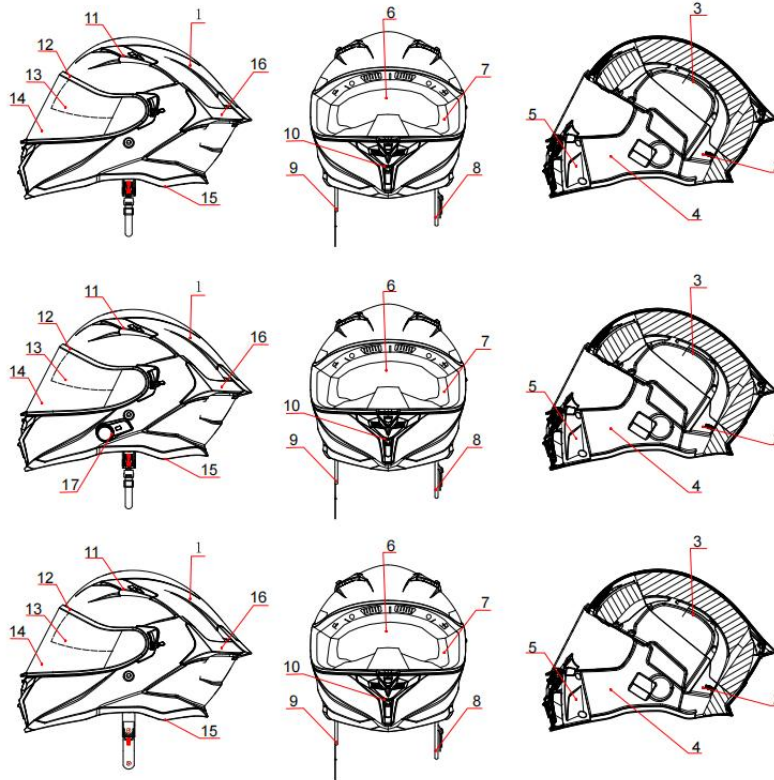

Number	Name	Material	Number	Name	Material
1	Shell	ABS	10	Mouth Vent	PC
2	Main Protective Padding	EPS	11	Front air vents	PC
3	Top Protective Padding	EPS	12	Eye Trim	PVC
4	Ear Protective Padding	EPS	13	Sun Shield	PC
5	Mouth Protective Padding	EPS	14	Visor	PC
6	Comfort Padding	Compound Sponge + Cloth	15	Bottom Trim	PVC
7	Ear Comfort Padding	Compound Sponge + Cloth +PP	16	Rear Vent	PC
8	Chin strap(left)	Nylon	17	<u>Additional Device</u>	<u>PC</u>
9	Chin strap(right)	Nylon			
Description	H153 Helmet		Code No.:	H153	
Manufacturer:	SHANGHAI HEHUI SAFETY PRODUCTS MANUFACTURE CO., LTD.				
Address:	NO.8 FENGJIN ROAD XIDU INDUSTRIAL DEVELOPMENT ZONE FENGXIAN DISTRICT SHANGHAI CHINA				
Drawn by:	Tang Kun Rong	Checked by:	Li Ling Song	Approved by:	Zhu Yong
Date:	04.11.2022	Date:	04.11.2022	Date:	04.11.2022

R22 E1*22R06/01*300939*01



Type : H153
 Manufacture : SHANGHAI HEHUI SAFETY PRODUCTS
 MANUFACTURE CO., LTD.

04.11.2022
 Page 6 of 21

Annex 2: Drawing of the sun shield

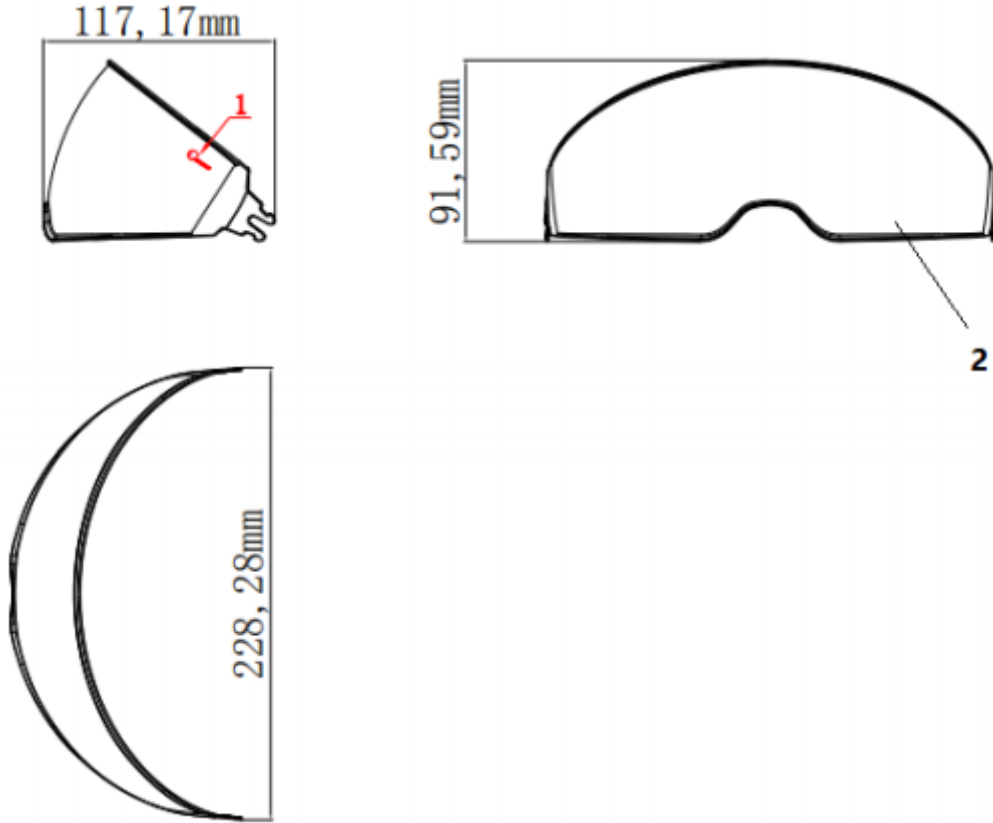

Number	Name	Material	Number	Name	Material
1	Sun Shield	PC	2	Warning	Daytime use only
Description	H153 Sun Shield		Code No.:	H153.13	
Manufacturer:	SHANGHAI HEHUI SAFETY PRODUCTS MANUFACTURE CO., LTD.				
Address:	NO.8 FENGJIN ROAD XIDU INDUSTRIAL DEVELOPMENT ZONE FENGXIAN DISTRICT SHANGHAI CHINA				
Drawn by:	Tang Kun Rong	Checked by:	Li Ling Song	Approved by:	Zhu Yong
Date:	28.06.2022	Date:	28.06.2022	Date:	28.06.2022

R22 E1*22R06/01*300939*01

INFORMATION DOCUMENT

R22-H153-01



Type : H153
 Manufacture : SHANGHAI HEHUI SAFETY PRODUCTS
 MANUFACTURE CO., LTD.

04.11.2022

Page 7 of 21

Annex 3: Drawing of the shell

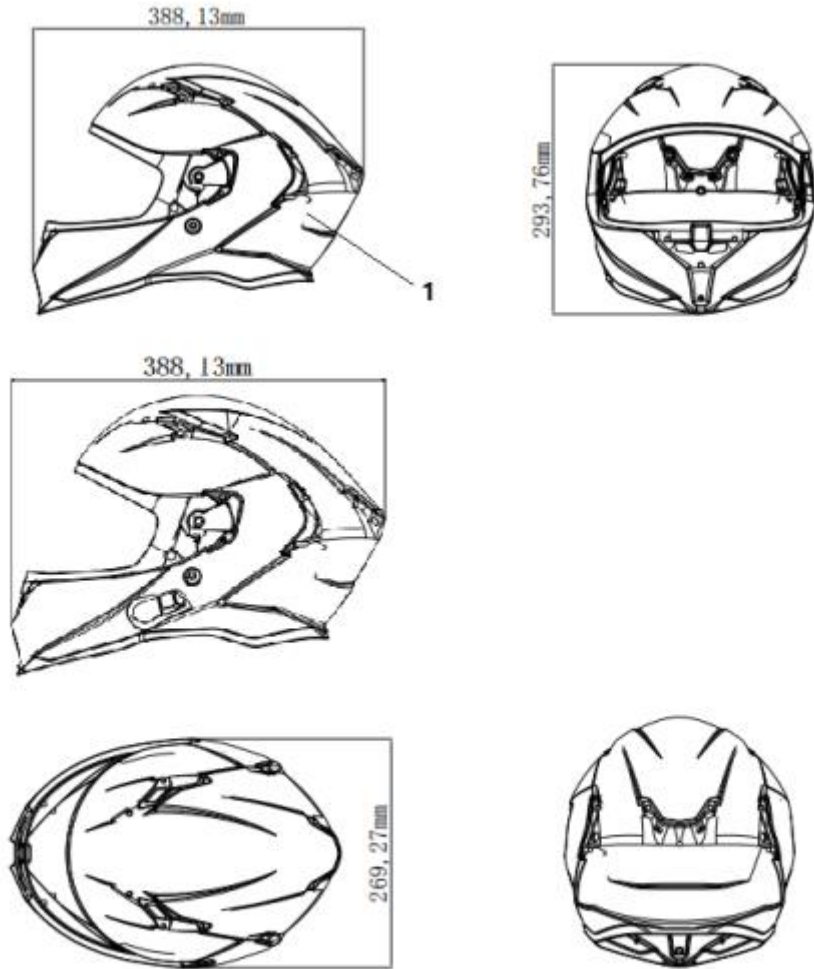

Unit: mm

Number	Name	Material	Number	Name	Material
1	Shell	ABS			
Description	H153 Large Shell		Code No.:	H153.1	
Manufacturer:	SHANGHAI HEHUI SAFETY PRODUCTS MANUFACTURE CO., LTD.				
Address:	NO.8 FENGJIN ROAD XIDU INDUSTRIAL DEVELOPMENT ZONE FENGXIAN DISTRICT SHANGHAI CHINA				
Drawn by:	Tang Kun Rong	Checked by:	Li Ling Song	Approved by:	Zhu Yong
Date:	28.06.2022	Date:	28.06.2022	Date:	28.06.2022

R22 E1*22R06/01*300939*01



Type : H153
 Manufacture : SHANGHAI HEHUI SAFETY PRODUCTS
 MANUFACTURE CO., LTD.

04.11.2022
 Page 8 of 21

Annex 4: Drawing of the protective padding

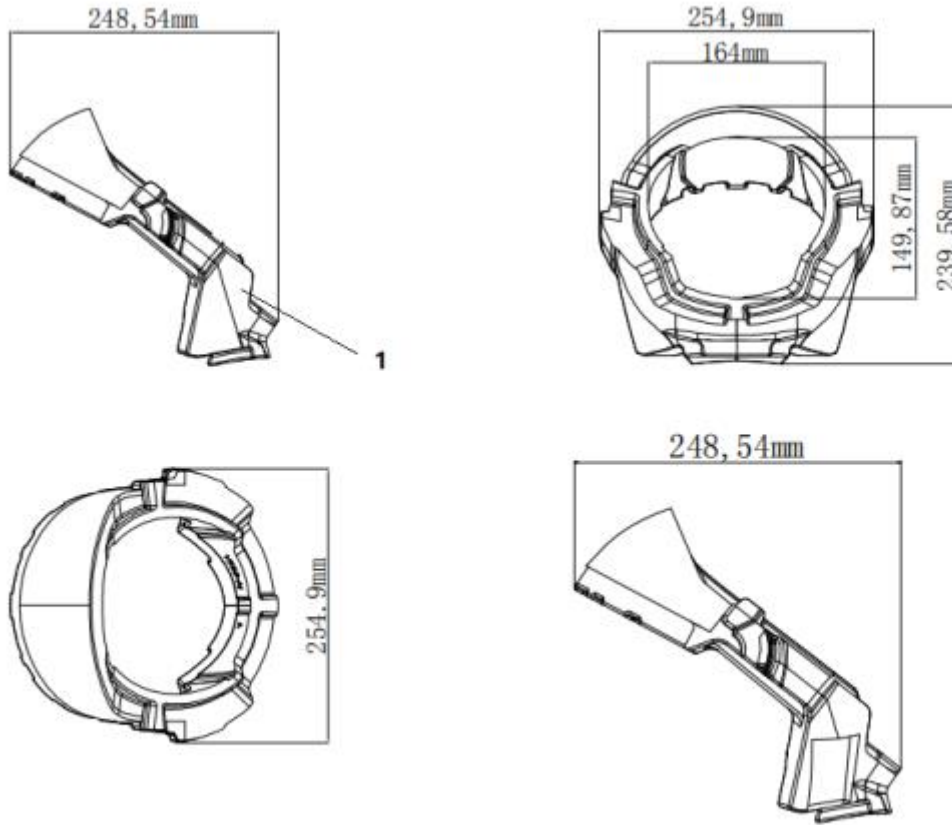

Unit: mm

R22 E1*22R06/01*300939*01

Number	Name	Material	Number	Name	Material
1	Main Protective Padding	EPS			
Description	H153 Medium Main Protective Padding(suit for sizes XS-M)		Code No.:	H153.2-M	
Manufacturer:	SHANGHAI HEHUI SAFETY PRODUCTS MANUFACTURE CO., LTD.				
Address:	NO.8 FENGJIN ROAD XIDU INDUSTRIAL DEVELOPMENT ZONE FENGXIAN DISTRICT SHANGHAI CHINA				
Drawn by:	Tang Kun Rong	Checked by:	Li Ling Song	Approved by:	Zhu Yong
Date:	28.06.2022	Date:	28.06.2022	Date:	28.06.2022

INFORMATION DOCUMENT

R22-H153-01



Type : H153
 Manufacture : SHANGHAI HEHUI SAFETY PRODUCTS
 MANUFACTURE CO., LTD.

04.11.2022

Page 9 of 21

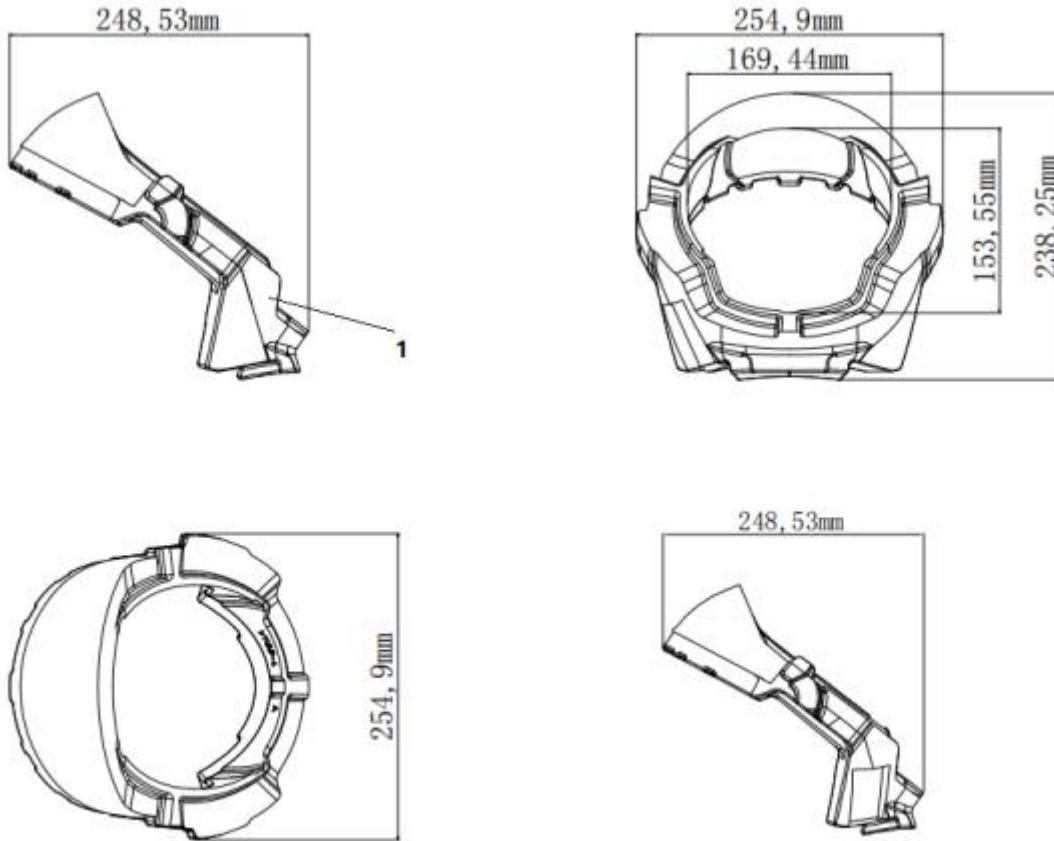

Unit: mm

Number	Name	Material	Number	Name	Material
1	Main Protective Padding	EPS			
Description	H153 Large Main Protective Padding(suit for sizes L-XL)		Code No.:	H153.2-L	
Manufacturer:	SHANGHAI HEHUI SAFETY PRODUCTS MANUFACTURE CO., LTD.				
Address:	NO.8 FENGJIN ROAD XIDU INDUSTRIAL DEVELOPMENT ZONE FENGXIAN DISTRICT SHANGHAI CHINA				
Drawn by:	Tang Kun Rong	Checked by:	Li Ling Song	Approved by:	Zhu Yong
Date:	28.06.2022	Date:	28.06.2022	Date:	28.06.2022

R22 E1*22R06/01*300939*01

INFORMATION DOCUMENT

R22-H153-01



Type : H153
 Manufacture : SHANGHAI HEHUI SAFETY PRODUCTS
 MANUFACTURE CO., LTD.

04.11.2022

Page 10 of 21

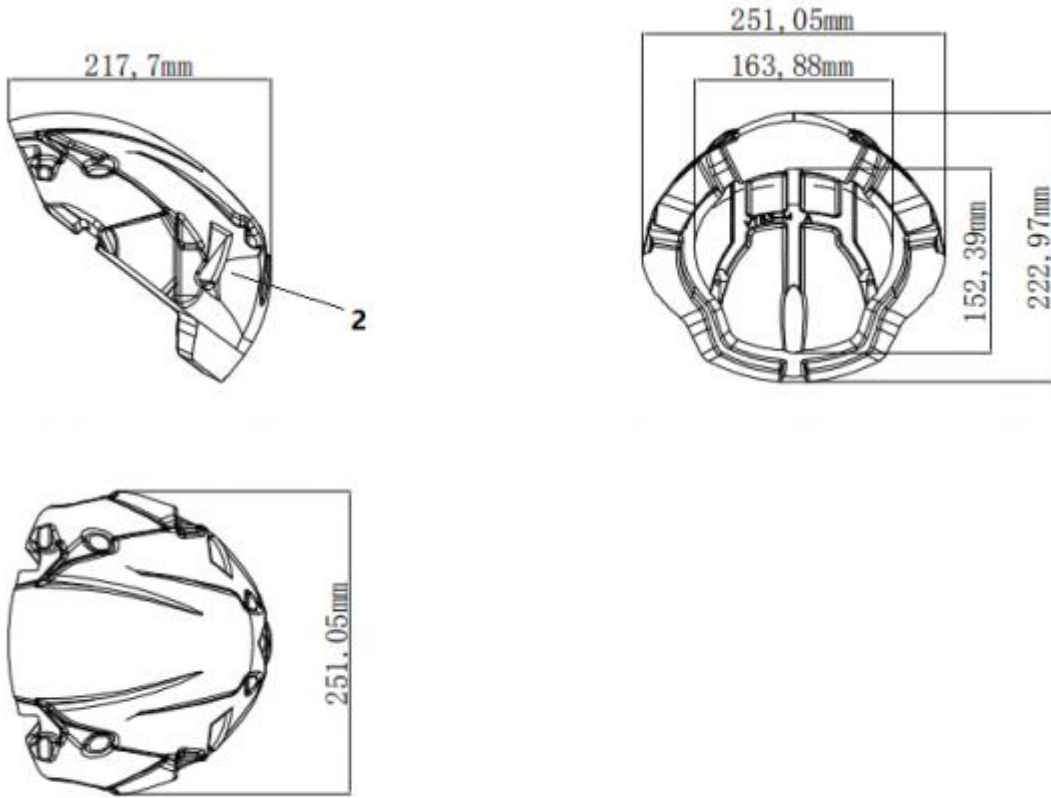

Unit: mm

Number	Name	Material	Number	Name	Material
2	Top Protective Padding	EPS			
Description	H153 Medium Top Protective Padding(suit for sizes XS-M)		Code No.:	H153.3-M	
Manufacturer:	SHANGHAI HEHUI SAFETY PRODUCTS MANUFACTURE CO., LTD.				
Address:	NO.8 FENGJIN ROAD XIDU INDUSTRIAL DEVELOPMENT ZONE FENGXIAN DISTRICT SHANGHAI CHINA				
Drawn by:	Tang Kun Rong	Checked by:	Li Ling Song	Approved by:	Zhu Yong
Date:	28.06.2022	Date:	28.06.2022	Date:	28.06.2022

R22 E1*22R06/01*300939*01

INFORMATION DOCUMENT

R22-H153-01



Type : H153
 Manufacture : SHANGHAI HEHUI SAFETY PRODUCTS
 MANUFACTURE CO., LTD.

04.11.2022

Page 11 of 21

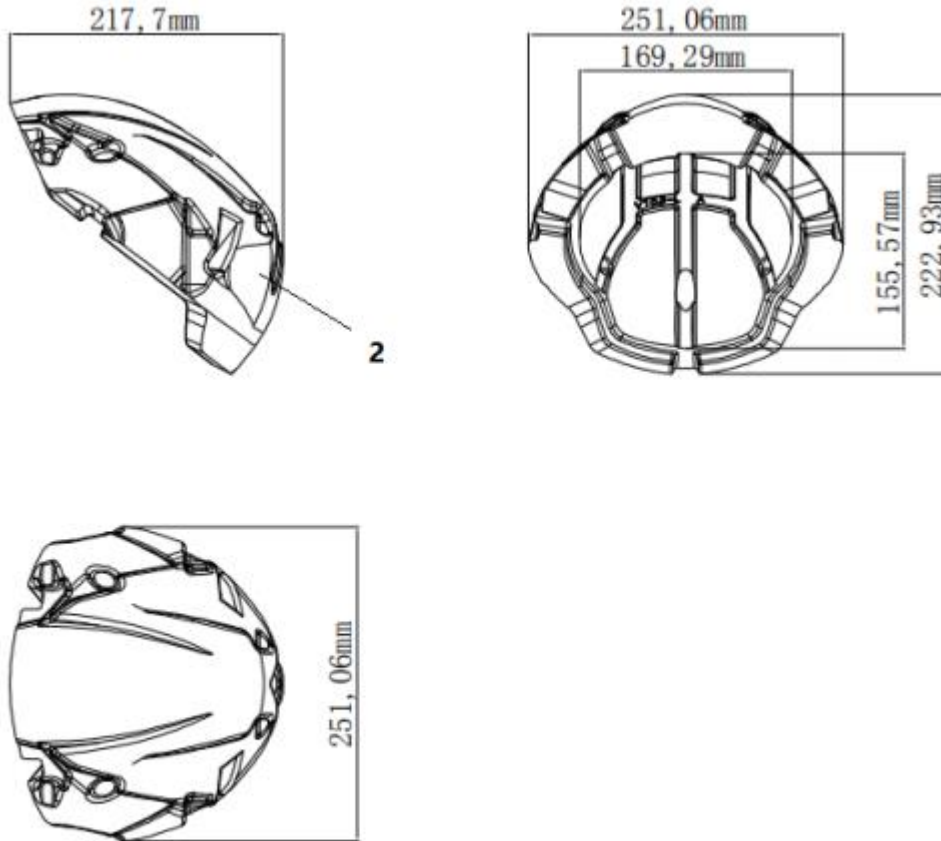

Unit: mm

Number	Name	Material	Number	Name	Material
2	Top Protective Padding	EPS			
Description	H153 Large Top Protective Padding(suit for sizes L-XL)		Code No.:	H153.3-L	
Manufacturer:	SHANGHAI HEHUI SAFETY PRODUCTS MANUFACTURE CO., LTD.				
Address:	NO.8 FENGJIN ROAD XIDU INDUSTRIAL DEVELOPMENT ZONE FENGXIAN DISTRICT SHANGHAI CHINA				
Drawn by:	Tang Kun Rong	Checked by:	Li Ling Song	Approved by:	Zhu Yong
Date:	28.06.2022	Date:	28.06.2022	Date:	28.06.2022

R22 E1*22R06/01*300939*01

INFORMATION DOCUMENT

R22-H153-01



Type : H153
 Manufacture : SHANGHAI HEHUI SAFETY PRODUCTS
 MANUFACTURE CO., LTD.

04.11.2022

Page 12 of 21

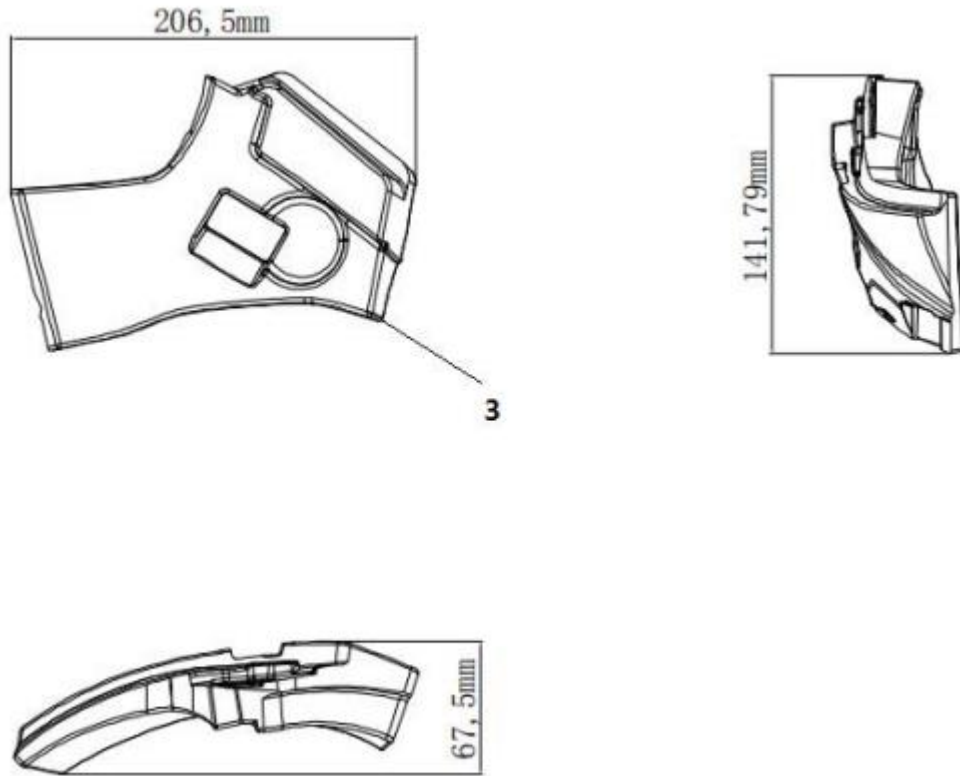

Unit: mm

R22 E1*22R06/01*300939*01

Number	Name	Material	Number	Name	Material
3	Ear Protective Padding	EPS			
Description	H153 Medium Ear Protective Padding(suit for sizes XS-M)		Code No.:	H153.4-M	
Manufacturer:	SHANGHAI HEHUI SAFETY PRODUCTS MANUFACTURE CO., LTD.				
Address:	NO.8 FENGJIN ROAD XIDU INDUSTRIAL DEVELOPMENT ZONE FENGXIAN DISTRICT SHANGHAI CHINA				
Drawn by:	Tang Kun Rong	Checked by:	Li Ling Song	Approved by:	Zhu Yong
Date:	28.06.2022	Date:	28.06.2022	Date:	28.06.2022

INFORMATION DOCUMENT

R22-H153-01



Type : H153
 Manufacture : SHANGHAI HEHUI SAFETY PRODUCTS
 MANUFACTURE CO., LTD.

04.11.2022

Page 13 of 21

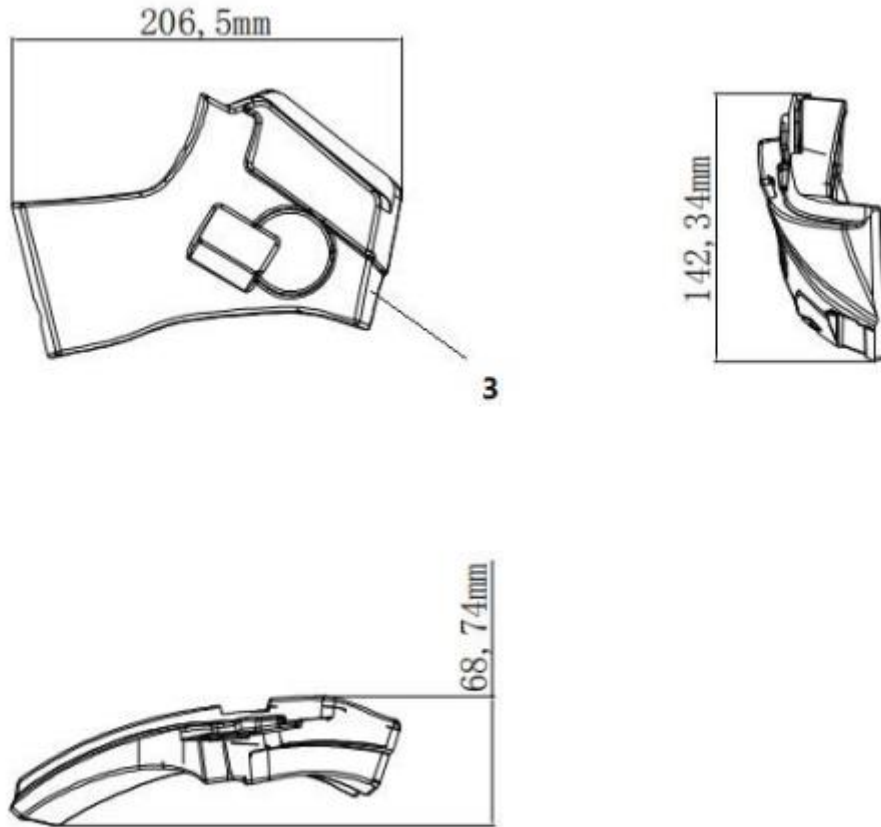

Unit: mm

Number	Name	Material	Number	Name	Material
3	Ear Protective Padding	EPS			
Description	H153 Larges Ear Protective Padding(suit for sizes L-XL)		Code No.:	H153.4-L	
Manufacturer:	SHANGHAI HEHUI SAFETY PRODUCTS MANUFACTURE CO., LTD.				
Address:	NO.8 FENGJIN ROAD XIDU INDUSTRIAL DEVELOPMENT ZONE FENGXIAN DISTRICT SHANGHAI CHINA				
Drawn by:	Tang Kun Rong	Checked by:	Li Ling Song	Approved by:	Zhu Yong
Date:	28.06.2022	Date:	28.06.2022	Date:	28.06.2022

R22 E1*22R06/01*300939*01

INFORMATION DOCUMENT

R22-H153-01



Type : H153
 Manufacture : SHANGHAI HEHUI SAFETY PRODUCTS
 MANUFACTURE CO., LTD.

04.11.2022

Page 14 of 21

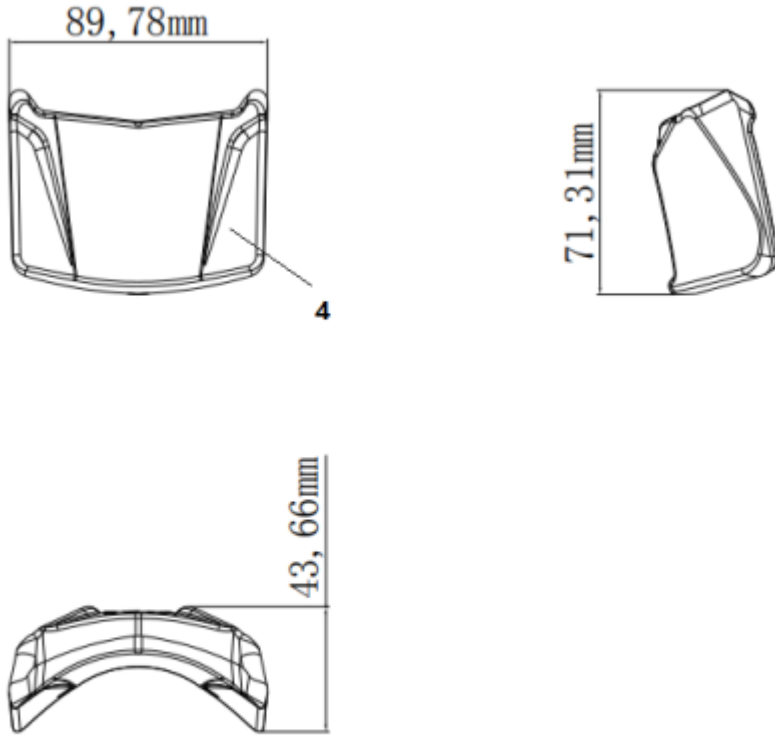

Unit: mm

Number	Name	Material	Number	Name	Material
4	Mouth Protective Padding	EPS			
Description	H153 Mouth Protective Padding(suit for sizes XS-XL)		Code No.:	H153.5	
Manufacturer:	SHANGHAI HEHUI SAFETY PRODUCTS MANUFACTURE CO., LTD.				
Address:	NO.8 FENGJIN ROAD XIDU INDUSTRIAL DEVELOPMENT ZONE FENGXIAN DISTRICT SHANGHAI CHINA				
Drawn by:	Tang Kun Rong	Checked by:	Li Ling Song	Approved by:	Zhu Yong
Date:	28.06.2022	Date:	28.06.2022	Date:	28.06.2022

R22 E1*22R06/01*300939*01



Type : H153
 Manufacture : SHANGHAI HEHUI SAFETY PRODUCTS
 MANUFACTURE CO., LTD.

04.11.2022

Page 15 of 21

Annex 5: Drawing of the comfort padding

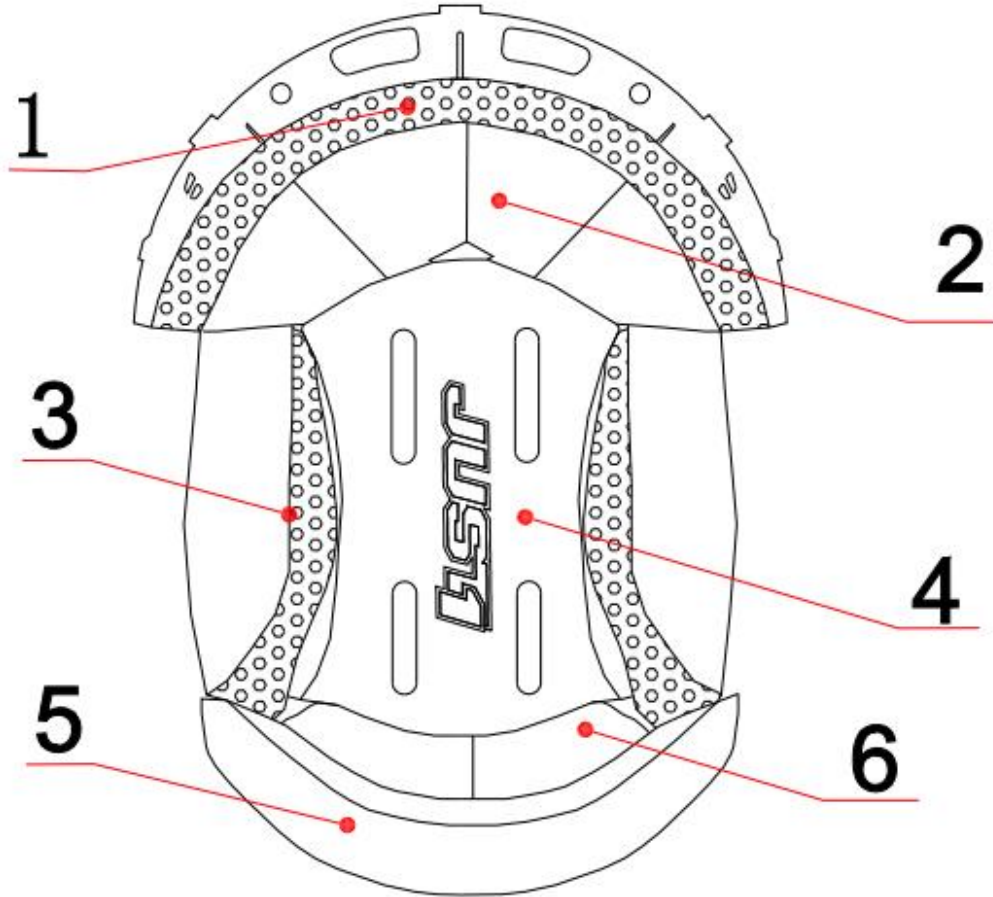

R22 E1*22R06/01*300939*01

Number	Name	Material	Number	Name	Material
1	Front ending	Compound Sponge	2	Front part	Compound Sponge
3	Lining Facing(L/R)	Compound Sponge	4	Crown	Compound Sponge
5	Back cover	Compound Sponge	6	Back part	Compound Sponge
Description	H153 Comfort Padding		Code No.:	H153.6	
Manufacturer:	SHANGHAI HEHUI SAFETY PRODUCTS MANUFACTURE CO., LTD.				
Address:	NO.8 FENGJIN ROAD XIDU INDUSTRIAL DEVELOPMENT ZONE FENGXIAN DISTRICT SHANGHAI CHINA				
Drawn by:	Tang Kun Rong	Checked by:	Li Ling Song	Approved by:	Zhu Yong
Date:	28.06.2022	Date:	28.06.2022	Date:	28.06.2022

INFORMATION DOCUMENT

R22-H153-01



Type : H153
 Manufacture : SHANGHAI HEHUI SAFETY PRODUCTS
 MANUFACTURE CO., LTD.

04.11.2022

Page 16 of 21

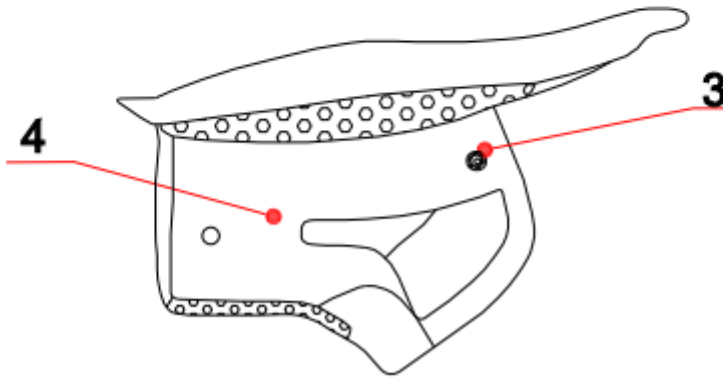
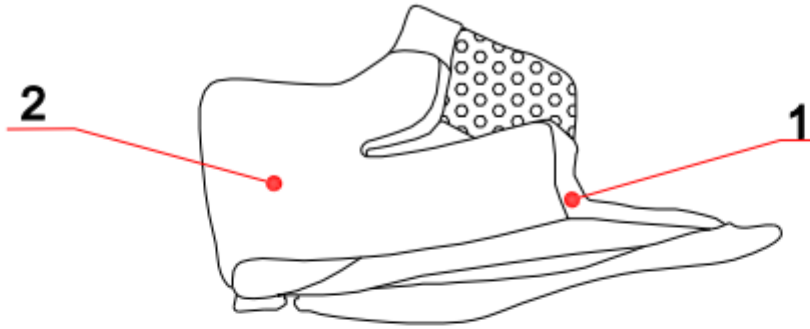

R22 E1*22R06/01*300939*01

Number	Name	Material	Number	Name	Material
1	Piping of the upper earmuffs	Fabric	2	Upper earmuffs surface	Compound Sponge
3	Snap button(female)	PA	4	PP sheet of the upper earmuffs	PP
Description	H153 Ear Comfort Padding		Code No.:	H153.7	
Manufacturer:	SHANGHAI HEHUI SAFETY PRODUCTS MANUFACTURE CO., LTD.				
Address:	NO.8 FENGJIN ROAD XIDU INDUSTRIAL DEVELOPMENT ZONE FENGXIAN DISTRICT SHANGHAI CHINA				
Drawn by:	Tang Kun Rong	Checked by:	Li Ling Song	Approved by:	Zhu Yong
Date:	28.06.2022	Date:	28.06.2022	Date:	28.06.2022



Type : H153
 Manufacture : SHANGHAI HEHUI SAFETY PRODUCTS
 MANUFACTURE CO., LTD.

04.11.2022

Page 17 of 21

Annex 6: Drawing of the retention system

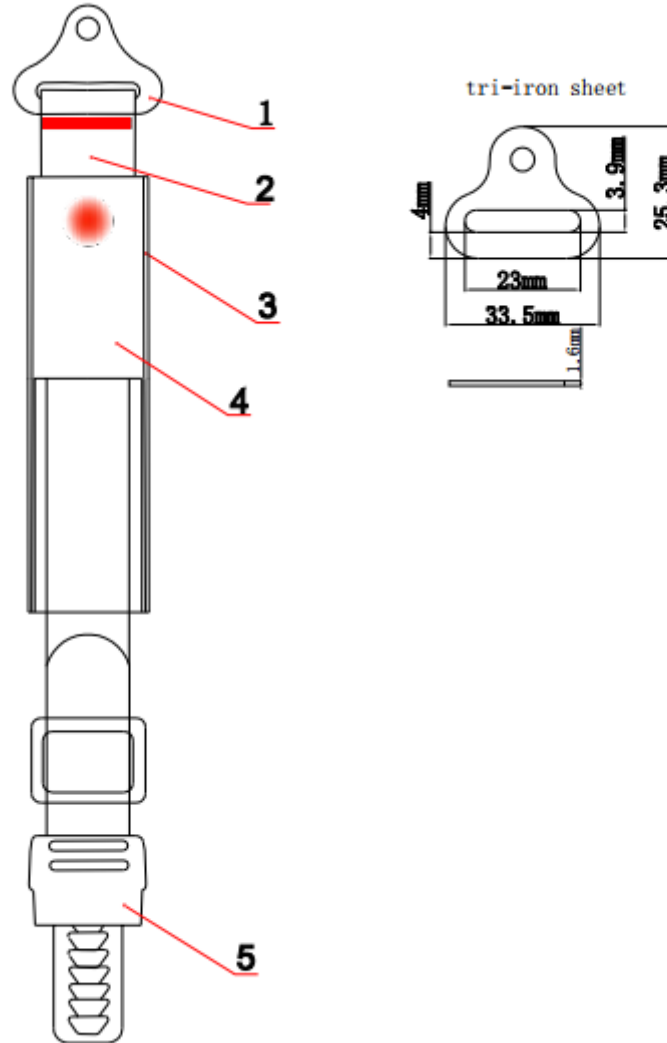

R22 E1*22R06/01*300939*01

Number	Name	Material	Number	Name	Material
1	Tri-iron sheet	sheet	2	Short-strap	Nylon
3	Piping cloth	fabric	4	Wearing cloth	Compound Sponge
5	Quick release buckle(male)	POM+Fe			
Description	H153 Retention System (Right)		Code No.:	H153.9	
Manufacturer:	SHANGHAI HEHUI SAFETY PRODUCTS MANUFACTURE CO., LTD.				
Address:	NO.8 FENGJIN ROAD XIDU INDUSTRIAL DEVELOPMENT ZONE FENGXIAN DISTRICT SHANGHAI CHINA				
Drawn by:	Tang Kun Rong	Checked by:	Li Ling Song	Approved by:	Zhu Yong
Date:	28.06.2022	Date:	28.06.2022	Date:	28.06.2022

INFORMATION DOCUMENT

R22-H153-01



Type : H153
 Manufacture : SHANGHAI HEHUI SAFETY PRODUCTS
 MANUFACTURE CO., LTD.

04.11.2022

Page 18 of 21

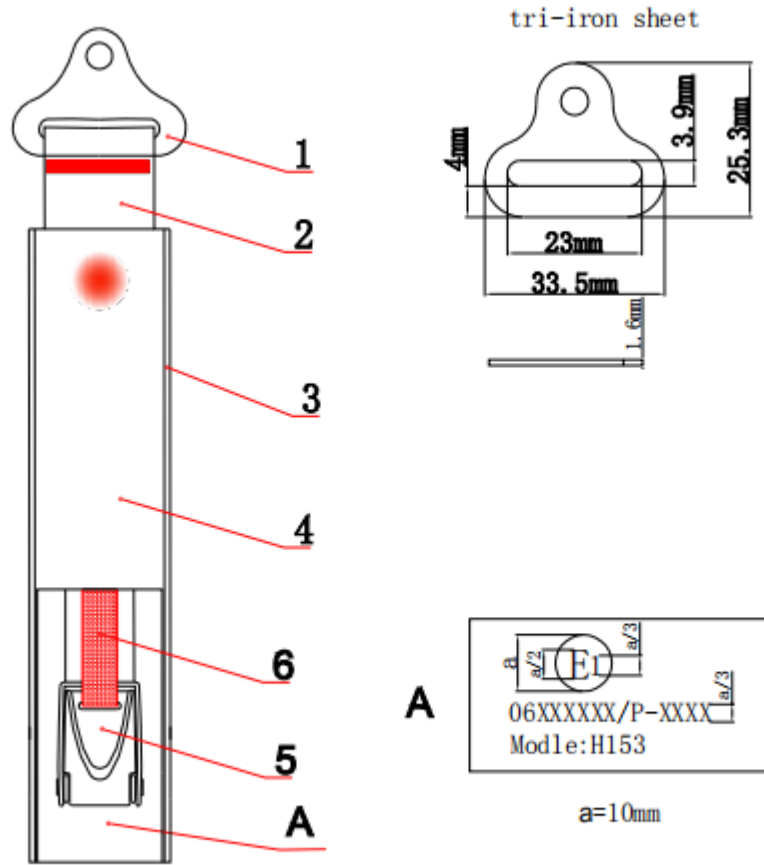

R22 E1*22R06/01*300939*01

Number	Name	Material	Number	Name	Material
1	Tri-iron sheet	sheet	2	Short-strap	Nylon
3	Piping cloth	fabric	4	Wearing cloth	Compound Sponge
5	Quick release buckle(male)	POM+Fe			
Description	H153 Retention System (left)		Code No.:	H153.8	
Manufacturer:	SHANGHAI HEHUI SAFETY PRODUCTS MANUFACTURE CO., LTD.				
Address:	NO.8 FENGJIN ROAD XIDU INDUSTRIAL DEVELOPMENT ZONE FENGXIAN DISTRICT SHANGHAI CHINA				
Drawn by:	Tang Kun Rong	Checked by:	Li Ling Song	Approved by:	Zhu Yong
Date:	28.06.2022	Date:	28.06.2022	Date:	28.06.2022

INFORMATION DOCUMENT

R22-H153-01



Type : H153
 Manufacture : SHANGHAI HEHUI SAFETY PRODUCTS
 MANUFACTURE CO., LTD.

04.11.2022

Page 19 of 21

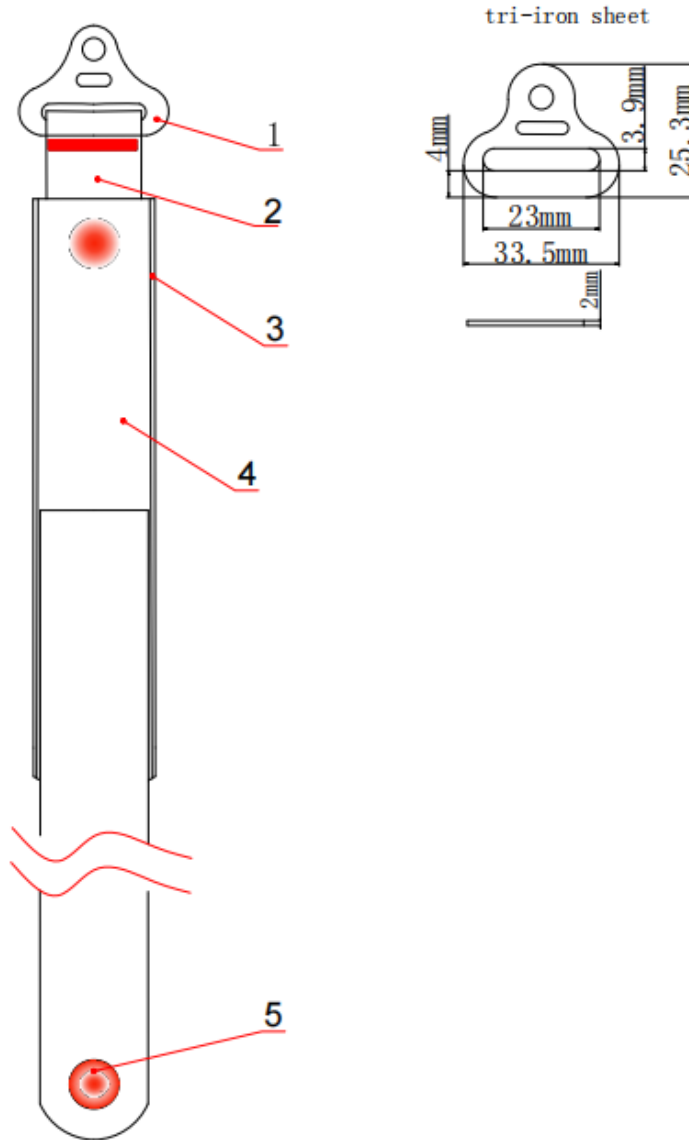

R22 E1*22R06/01*300939*01

Number	Name	Material	Number	Name	Material
1	Tri-iron sheet	sheet	2	Short-strap	Nylon
3	Piping cloth	fabric	4	Wearing cloth	Compound Sponge
5	Snap-male	PA			
Description	H153 Chin Strap(Right)		Code No.:	H153.9-1	
Manufacturer:	SHANGHAI HEHUI SAFETY PRODUCTS MANUFACTURE CO., LTD.				
Address:	NO.8 FENGJIN ROAD XIDU INDUSTRIAL DEVELOPMENT ZONE FENGXIAN DISTRICT SHANGHAI CHINA				
Drawn by:	Tang Kun Rong	Checked by:	Li Ling Song	Approved by:	Zhu Yong
Date:	04.11.2022	Date:	04.11.2022	Date:	04.11.2022

INFORMATION DOCUMENT

R22-H153-01



Type : H153
 Manufacture : SHANGHAI HEHUI SAFETY PRODUCTS
 MANUFACTURE CO., LTD.

04.11.2022

Page 20 of 21

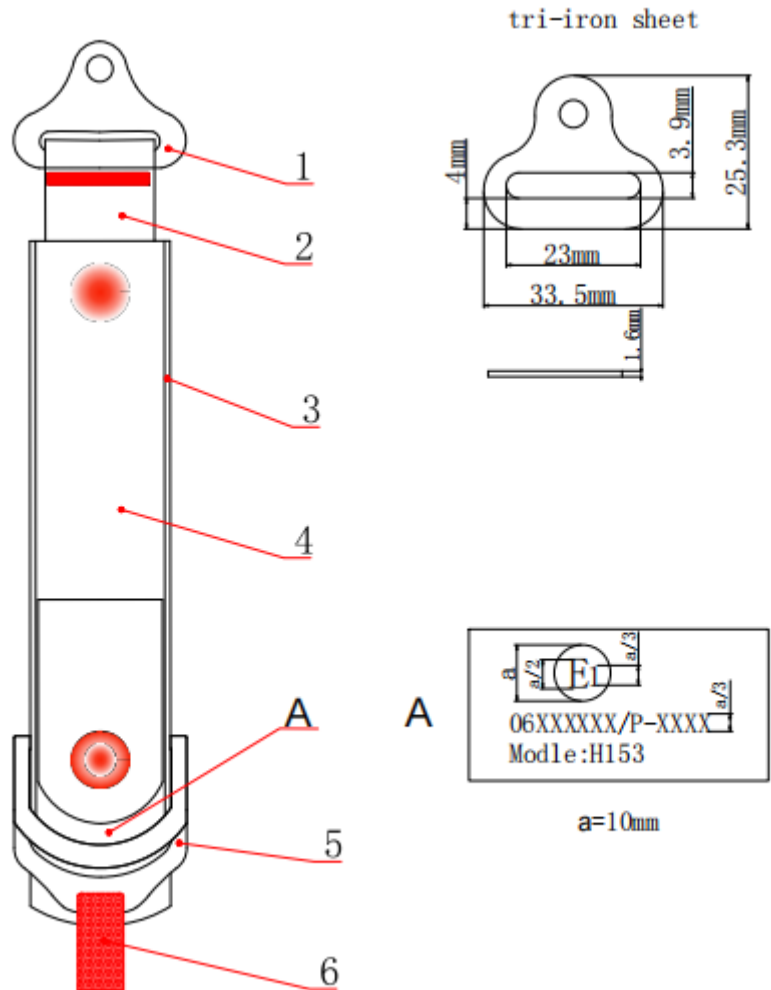

R22 E1*22R06/01*300939*01

Number	Name	Material	Number	Name	Material
1	Tri-iron sheet	sheet	2	Short-strap	Nylon
3	Piping cloth	fabric	4	Wearing cloth	Compound Sponge
5	Double D Ring	Al	6	Small-strap	Nylon(L*H:65*10mm)
Description	H153 Chin Strap(left)		Code No.:	H153.8-1	
Manufacturer:	SHANGHAI HEHUI SAFETY PRODUCTS MANUFACTURE CO., LTD.				
Address:	NO.8 FENGJIN ROAD XIDU INDUSTRIAL DEVELOPMENT ZONE FENGXIAN DISTRICT SHANGHAI CHINA				
Drawn by:	Tang Kun Rong	Checked by:	Li Ling Song	Approved by:	Zhu Yong
Date:	04.11.2022	Date:	04.11.2022	Date:	04.11.2022



Type : H153
Manufacture : SHANGHAI HEHUI SAFETY PRODUCTS
MANUFACTURE CO., LTD.

04.11.2022

Page 21 of 21

Annex 7: Information for wearer

WARNING

No helmet can protect the user from all possible and foreseeable impacts.

- 1. For adequate protection, this helmet must fit closely and be securely attached. Any helmet that has sustained a violent impact should be replaced.**
- 2. Visors (if fitted) with the marking indicating "daytime use only" are not suitable for use during the hours of darkness or in conditions of poor visibility. The fastening of visor is such that it will not be possible to remove it instantly from the line of sight with one hand should an emergency (such as headlamp glare or misting) occur.**
- 3. To maintain the full efficiency of the helmet, any modification to the structure of the helmet or its parts is not allowed.**
- 4. Do not apply paint, stickers, petrol or other solvents to this helmet. Hydrocarbons, cleaning fluids, paints, transfers or other extraneous additions will affect the shell material adversely.**

Shell is made by injection method using acrylonitrile butadiene styrene and polycarbonate blending thermoplastic. Lining is made of expanded polystyrene.

Important: read helmet user's guide for additional information prior to using your new helmet.

WARNING

- 1. TO CLEAN THE VISOR USE HOUSEHOLD WINDOW CLEANER AND A LINT FREE TOWEL ONLY. CAUSTIC CHEMICALS OR SOLVENT MUST NOT BE USED.**
- 2. BEFORE CLEANING VISOR, BE SURE TO BRUSH AWAY ANY LARGE PIECES OF DIRT.**
- 3. VISORS OR SUN SHIELD WITH THE MARKING "DAYTIME USE ONLY" ARE NOT SUITABLE FOR USE DURING THE HOURS OF DARKNESS OR IN CONDITIONS OF POOR VISIBILITY.**
- 4. THE SUN SHIELD SHALL ONLY BE USED IN COMBINATION WITH THE VISOR IN CLOSED POSITION TO ENSURE THE MECHANICAL PROTECTION OF THE EYES.**